

\*7,8,9,10,11,17 NUMBERED PARTS INCLUDED IN SEAL KIT.

#	Part No	Description	Qty
1	SPH210P-01	BODY ASSEMBLY	1
2	SPH210P-02	PISTON	1
3	SPH210P-03	PISTON CAP	1
4	SPH210P-04	SLIDER	2
5	SPH210P-05	SLIDER PIN	1
7	SPH210P-07	* O-RING	1
8	SPH210P-08	* BACKUP RING	2
9	SPH210P-09	* O-RING	2
10	SPH210P-10	* U-RING	1
11	SPH210P-11	* O-RING	2

#	Part No	Description	Qty
12	SPH210P-12	END CAP	1
13	SPH210P-13	SCREW	2
14	SPH210P-14	FIXUP SCREW	2
15	SPH210P-15	TIGHTENING SCREW	8
16	SPH210P-16	SWIVEL (BACK)	2
17	SPH210P-17	* O-RING	6
18	SPH210P-18	CIRCLE CLIP	2
19	SPH210P-19	SWIVEL (TOP) ASSY	1
20	SPH210P-20	BALL	1
21	SPH210P-21	BALL SEAT	1

#	Part No	Description	Qty
22	SPH210P-22	SPRING	1
23	SPH210P-23	SCREW	1
24	SPH210P-24	1/4" NIPPEL OUTER THREAD	2
25	SPH210P-25	1/4" MALE COUPLER OUTER THREAD	1
25B	SPH210P-25B	1/4" FEMALE COUPLER OUTER THREAD	1
26	SPH210P-26	SCREW	1
27	SPH210P-27	SCREW WITH SPRING	1
28	SPH210P-28	LINK PIN	1
29	SPH210P-00	SEAL KIT	1

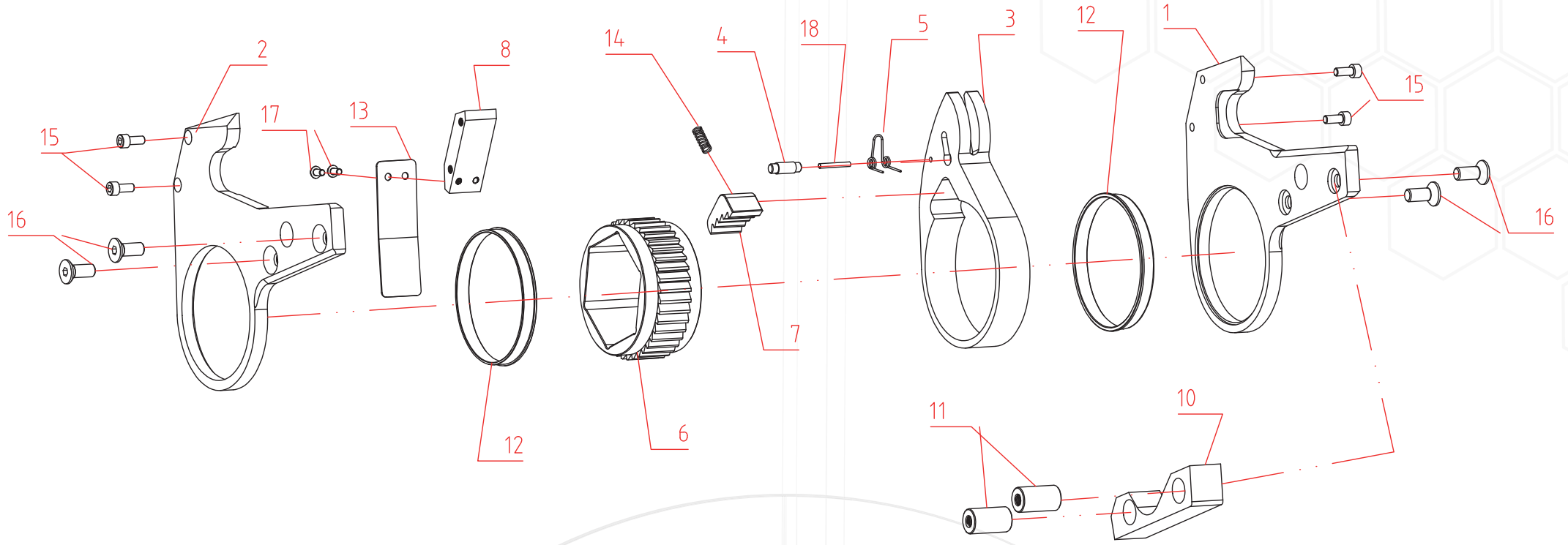

#	Part No	Description	Qty
1	SPH210C-01	RIGHT SIDE PLATE	1
2	SPH210C-02	LEFT SIDE PLATE	1
3	SPH210C-03	DRIVE PLATE	1
4	SPH210C-04	DRIVE PIN	1
5	SPH210C-05	SPRING	1
6	SPH210C-06	HEX RATCHET	1

#	Part No	Description	Qty
7	SPH210C-07	DRIVE SEGMENT	1
8	SPH210C-08	UPPER SPACER	1
10	SPH210C-10	LOWER SPACER	1
11	SPH210C-11	FIX ROTOR	2
12	SPH210C-12	COPPER SLEEVE	1
13	SPH210C-13	SHROUD	1

#	Part No	Description	Qty
14	SPH210C-14	SPRING	1
15	SPH210C-15	SIDE PLATE SCREW	4
16	SPH210C-16	SIDE PLATE SCREW	4
17	SPH210C-17	SCREW FOR SHROUD	2
18	SPH210C-18	PIN	1