



FLANGE TOOL INNOVATION

PRODUCT DATA SHEET

NS36TE

EXTERNAL HYDRAULIC NUT SPLITTER

NUT RANGE:

HEX NUT A/F: 50.8 mm - 65.0 mm (2.00" - 2.56")
H: Max 42.0 mm (1.65")

TOOL WEIGHT:

10.6 kg (23.4 lb)

KIT CONTENTS

- 1 x NS36TE Nut Splitter
- 1 x Spare Cutting Tip
- 1 x Spare Tip Retention Screw
- 1 x Spare Alignment Screw
- 1 x Set of Hex Keys
- 1 x Safety Lanyard
- 1 x Instruction Manual
- 1 x Carry Case

Product Code: NS36TEMIN



WEIGHTS AND DIMENSIONS

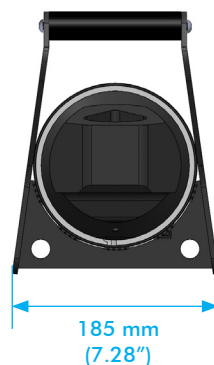
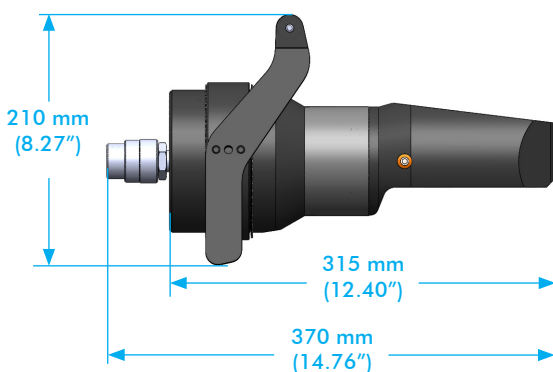

Tool Weight: 10.6 kg (23.4 lb)
Gross Weight: 13.6 kg (30.0 lb)

Carry Case Dimensions:
580 mm x 350 mm x 200 mm
(22.8" x 13.8" x 7.9")

Minimum Pump Oil Capacity:
230 cc (14.04 in³)

info@equalizerinternational.com
www.equalizerinternational.com

NS36TE

EXTERNAL HYDRAULIC NUT SPLITTER



FLANGE TOOL INNOVATION

RANGE OF APPLICATION

NUT SPLITTER	HEX NUT A/F	METRIC (COARSE)	UNC (STANDARD)	UNC (HEAVY)
NS12	17.5 mm - 30.0 mm (0.69" - 1.18")	M12 - M20	9/16" - 5/8"	1/2" - 5/8"
NS15	23.0 mm - 36.5 mm (0.91" - 1.44")	M16 - M22	5/8" - 7/8"	9/16" - 7/8"
NS20	32.0 mm - 51.0 mm (1.26" - 2.01")	M24 - M30	1" - 1 1/4"	7/8" - 1 1/8"
NS36	50.8 mm - 65.0 mm (2.00" - 2.56")	M33 - M42	1 3/8" - 1 5/8"	1 1/4" - 1 5/8"
NS50	65.0 mm - 80.0 mm (2.56" - 3.15")	M45 - M52	1 3/4" - 2"	1 5/8" - 2"
NS75	79.4 mm - 100.0 mm (3.13" - 3.94")	M56 - M68	2 1/4" - 2 1/2"	2" - 2 1/2"
NS100	98.4 mm - 115.0 mm (3.87" - 4.53")	M72 - M80	2 3/4" - 3"	2 1/2" - 3"

SPATIAL ENVELOPE

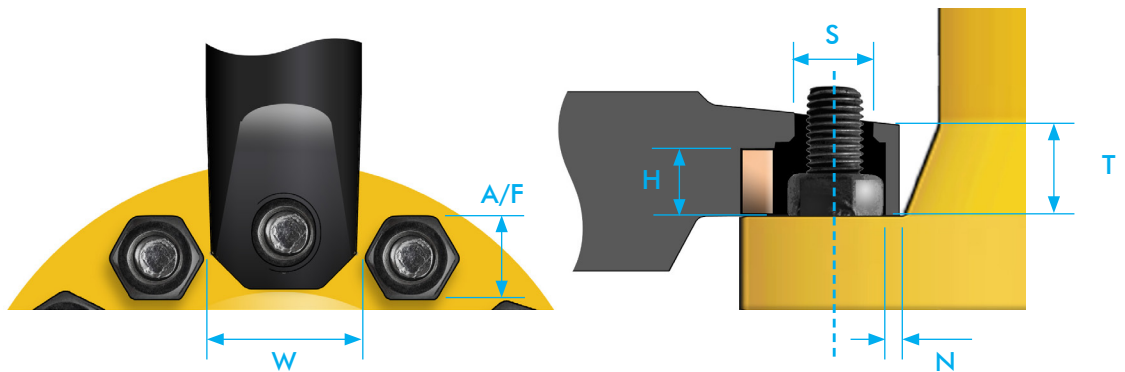

	DIMENSION	MEASURED FROM	MEASURED TO	MINIMUM	MAXIMUM
A/F	Across Flats	Nut Hex Flat	Nut Hex Flat	50.8 mm (2.00")	65.0 mm (2.56")
W	Clear Width	Side Obstruction	Side obstruction	105.0 mm (4.13")	-
S	Protruding Stud Diameter	Stud O/D	Stud OD	-	47.0 mm (1.85")
H	Cutting Height	Flange Face	Top of Nut	-	42.0 mm (1.65")
N	Nose Clearance	Nut Flat	Frontal Obstruction	16.5 mm (0.65")	-
T	Nose Height	Flange Face	Top of Nose	54 mm (2.13")	