



FLANGE TOOL INNOVATION

# PRODUCT DATA SHEET

## NS12TI

### INTEGRAL HYDRAULIC NUT SPLITTER

#### NUT RANGE:

HEX NUT	A/F:	17.5 mm - 30.0 mm (0.69" - 1.18")
	H:	Max 20.0 mm (0.79")

#### TOOL WEIGHT:

5.8 kg (12.8 lb)

#### KIT CONTENTS

- 1 x NS12TI Tool
- 1 x Spare Cutting Tip
- 1 x Spare Tip Retention Screw
- 1 x Spare Alignment Screw
- 1 x Set of Hex Keys
- 1 x Safety Lanyard
- 1 x Instruction Manual
- 1 x Carry Case

Product Code: NS12TISTD



#### WEIGHTS AND DIMENSIONS

Tool Weight:	5.8 kg (12.8 lb)
Gross Kit Weight:	9.0 kg (20.0 lb)

Carry Case Dimensions:  
580 mm x 350 mm x 180 mm  
(22.8" x 13.8" x 7.1")



# NS12TI

INTEGRAL HYDRAULIC NUT SPLITTER



FLANGE TOOL INNOVATION

## RANGE OF APPLICATION

NUT SPLITTER	HEX NUT A/F	METRIC (COARSE)	UNC (STANDARD)	UNC (HEAVY)
<b>NS12</b>	17.5 mm - 30.0 mm (0.69" - 1.18")	M12 - M20	9/16" - 5/8"	1/2" - 5/8"
<b>NS15</b>	23.0 mm - 36.5 mm (0.91" - 1.44")	M16 - M22	5/8" - 7/8"	9/16" - 7/8"
<b>NS20</b>	32.0 mm - 51.0 mm (1.26" - 2.01")	M24 - M30	1" - 1 1/4"	7/8" - 1 1/8"
<b>NS36</b>	50.8 mm - 65.0 mm (2.00" - 2.56")	M33 - M42	1 3/8" - 1 5/8"	1 1/4" - 1 5/8"
<b>NS50</b>	65.0 mm - 80.0 mm (2.56" - 3.15")	M45 - M52	1 3/4" - 2"	1 5/8" - 2"
<b>NS75</b>	79.4 mm - 100.0 mm (3.13" - 3.94")	M56 - M68	2 1/4" - 2 1/2"	2" - 2 1/2"
<b>NS100</b>	98.4 mm - 115.0 mm (3.87" - 4.53")	M72 - M80	2 3/4" - 3"	2 1/2" - 3"

## SPATIAL ENVELOPE

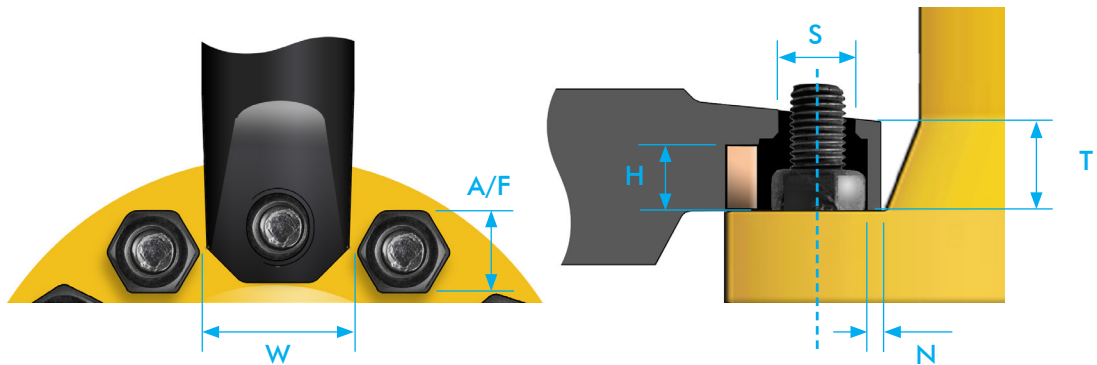

	DIMENSION	MEASURED FROM	MEASURED TO	MINIMUM	MAXIMUM
A/F	Across Flats	Nut Hex Flat	Nut Hex Flat	17.5 mm (0.69")	30.0 mm (1.18")
W	Clear Width	Side Obstruction	Side obstruction	53.5 mm (2.11")	-
S	Protruding Stud Diameter	Stud OD	Stud OD	-	24.5 mm (0.96")
H	Cutting Height	Flange Face	Top of Nut	-	20.0 mm (0.79")
N	Nose Clearance	Nut Flat	Frontal Obstruction	8.5 mm (0.33")	-
T	Nose Height	Flange Face	Top of Nose	26.5 mm (1.04")	