



Handtorque™ Small Diameter Series

Handtorque models HT30 and 60 have all the features of the Standard Series, but have a higher torque output for a given gearbox diameter.

- Reduced diameter allows better access, particularly on pipe flanges.
- Reaction taken from high strength spline.
- Reaction foot can slide on the spline to allow for sockets of various lengths.
- Anti Wind-Up Ratchet available on all models allowing safer and more practical operation.



HT60/25

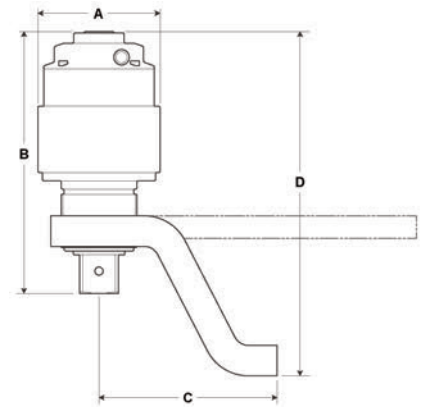

Alternative 350mm long, straight reaction plate; may be modified by customer to suit their applications.

HT30 Part No. 16686
HT60 Part No. 16687

Small Diameter Series

Model	Part No.	Range		Ratio	Input Square		A	B	C	D min	D max	Tool Weight	Reaction Weight
		N.m	lbf.ft		in	in							
30/5	18003	3000	2200	5:1	¾	1	108	192	140	224.2	252.4	5.0	2
30/5 Fitted with AWUR	18002	3000	2200	5:1	¾	1	108	187	140	219.7	247.9	6.1	2
30/15	18004	3000	2200	15:1	½	1	108	210.9	140	243.2	271.4	7.0	2
30/25 Fitted with AWUR	18006	3000	2200	25:1	½	1	108	210.9	140	243.2	241.4	7.0	2
60/25	18008	6000	4400	25:1	½	1½	119	256	174	311.5	337	10.6	4
60/75 Fitted with AWUR	18010	6000	4400	75:1	½	1½	119	283.2	174	340.5	366	12.1	4
60/125 Fitted with AWUR	18012	6000	4400	125:1	½	1½	119	284.7	174	340.5	366	12.1	4