

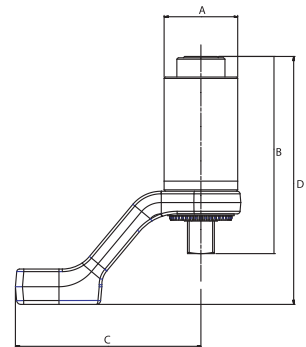

HandTorque™ Compact Series HT-52 & HT-72

- Compact size allows easy access to applications.
- Light weight for torque capacity.
- Supplied as standard with an aluminium reaction arm. Other options are available on request, including customised reactions.
- Robust, 48 tooth Anti Wind-Up Ratchet (AWUR) contains the forces generated during tightening for safe and easy operation.
- Guaranteed multiplication accuracy of $\pm 4\%$.
- Each multiplier is supplied with its own unique calibration certificate allowing the accurate calculation of input torque for critical applications
- Supplied in a carry case



HT-52 and HT-72

Model	Part No.	Range		Ratio	Input Square in	Output Square in	A mm	B mm	C mm	D mm	Tool Weight kg	Reaction Weight kg
		N.m	lbf.ft									
HT-52/4.5	180200	1000	740	4.5:1	½	¾	52	115	131	150.3	1.0	0.85
HT-52/22	180201	1000	740	22:1	¾	¾	52	139	131	175	1.3	0.85
HT-52/22	180202	1000	740	22:1	½	¾	52	139	131	175	1.4	0.85
HT-52/22 Fitted with AWUR	180203	1000	740	22:1	¾	¾	52	153	131	189	1.4	0.85
HT-52/22 Fitted with AWUR	180204	1000	740	22:1	½	¾	52	153	131	189	1.4	0.85
HT-52/22 Fitted with AWUR	180205	1000	740	22:1	¾	1	52	157.9	131	190	1.4	0.85
HT-52/22 Fitted with AWUR	180206	1000	740	22:1	½	1	52	156.6	131	190	1.4	0.85
HT-72/5	180207	1000	740	5:1	½	¾	72	144.1	165.5	188.1	2.4	0.66
HT-72/5	180208	1500	1100	5:1	½	1	72	143.6	165.5	188.1	2.4	0.66
HT-72/5	180209	1000	740	5:1	¾	¾	72	163.2	165.5	207.6	2.4	0.66
HT-72/5	180210	2000	1450	5:1	¾	1	72	163.2	165.5	207.6	2.4	0.66
HT-72/27	180211	1000	740	27:1	½	¾	72	164.8	165.5	208.7	2.7	0.66
HT-72/27	180212	2000	1450	27:1	½	1	72	164.8	165.5	208.7	2.7	0.66
HT-72/27 Fitted with AWUR	180213	1000	740	27:1	½	¾	72	182.3	165.5	226.4	3.0	0.66
HT-72/27 Fitted with AWUR	180214	2000	1450	27:1	½	1	72	182.3	165.5	226.4	3.0	0.66

Handtorque™ Compact Series HT-92 & HT-119

- Compact size allows easy access to applications.
- Light weight for torque capacity.
- Supplied as standard with an aluminium reaction arm. Other options are available on request, including customised reactions.
- Robust, 48 tooth Anti Wind-Up Ratchet (AWUR) contains the forces generated during tightening for safe and easy operation.
- Guaranteed multiplication accuracy of $\pm 4\%$.
- Each multiplier is supplied with its own unique calibration certificate allowing the accurate calculation of input torque for critical applications
- Supplied in a carry case

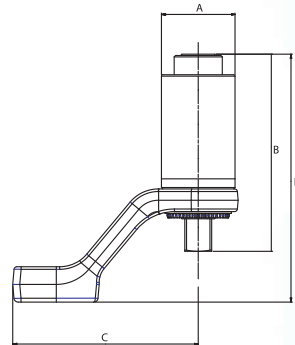

HT-92 and HT-119

Model	Part No.	Range		Ratio	Input Square	Output Square	A	B	C	D	Tool Weight	Reaction Weight
		N.m	lbf.ft		in	in	mm	mm	mm	mm	kg	kg
HT-92/25 Fitted with AWUR	18092	4000	2950	25:1	½	1	92	220.3	204.9	277.4	5.4	1.35
HT-119/25 Fitted with AWUR	18091	7000	5000	25:1	½	1 ½	119.2	252.4	198.6	329.7	9.3	2.10

Handtorque™ Compact Series Kits

For convenience, it is now possible to purchase a torque multiplier from the 'Compact Series' packaged with the appropriate torque wrench. This allows the operator to arrive at the bolting application with everything needed in one robust carry case. Space has also been allowed in the carry case for accessories such as sockets.

The torque wrench and torque multiplier are each supplied with their own unique calibration certificate, allowing accurate calculation of input torque to the multiplier for critical applications.

Also available with N.m or lbf.ft only torque wrenches.

Handtorque™ Kits

Part No.	Handtorque Supplied	Torque Wrench Supplied	Kit Length	Kit Width	Kit Depth	Kit Weight
			mm	mm	mm	Kg
18186	HT-52, 22:1, ¾" Out	TTi60 (Dual Scale)	360	228	135	5.4
18189	HT-52, 22:1, 1" Out	TTi60 (Dual Scale)	360	225	135	5.47
18192	HT-72, 27:1, 1" Out	TTi100 (Dual Scale)	459	319	160	7.7
18195	HT-92, 25:1, 1" Out	TTi200 (Dual Scale)	459	319	160	12.25

