

AIR DRIVEN HYDROTEST PUMPS - STANDARD FLOW**LARZEP advantages**

- 10 Models Available, from 70 bar to 2.900 bar.
- Engineered and designed for easy operation.
- Compact and lightweight steel frame for full protection and handling.
- Fully integrated and protected pressure gauge.
- Clearly labelled controls for improved safety.
- Supplied with air inlet connector, air filter, air pressure regulator, air lubricator, air pressure gauge, air pressure limit valve, pump on/off control, oil pressure gauge.
- All pumps work with water or oil.
- All pumps supplied complete with a full test certificate as standard.
- High pressure fittings and any length of high pressure hose available from stock.
- Oil / Water Reservoir: 7 litres.
- Working Air Pressure: 1.7 to 6.9 bar.
- Air Inlet Port: 1/2" NPTF Female.
- Air Consumption: 0,79 m³/min.
- Sound Level: 90 dBA.
- Weight: 20 kg.
- Hydraulic Pressure Gauge: Dual scale bar/psi.
- Options: Chart recorders - Integral or free standing, Chart recorder pens and charts, Stroke counter, Stainless steel framework, External connection to liquid supply to increase available fluid during testing, USB connection for laptop including software.

Additional Hydrotest Pump models

- High flow pumps Hydrotest Pumps (Double the speed of standard) - 10 Models Available.
- Ultra high flow double acting Hydrotest Pumps up to 35 litres per minute.
- Tailor made custom Hydrotest Sytems/Test Rigs for multiple testing.
- Electric Hydrotest Pumps.



HYDROTEST PUMPS



HAP

7 litres

70-2.900 bar

PUMPS

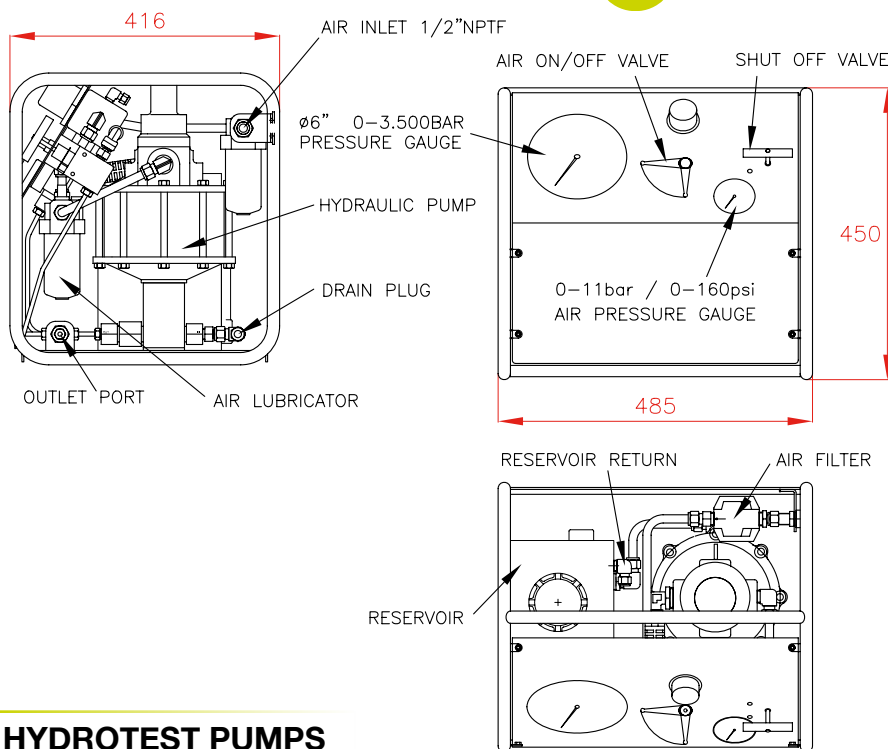

Chart Recorder

HYDROTEST PUMPS

Hydrotest Pump	Maximum Hydraulic Pressure (bar)			Flow (l/min)			Outlet Port
	Air 6.9 bar	Air 5.1 bar	Air 4.1 bar	20% Max. P	50% Max. P	80% Max. P	
LARZEP							Female
HAP0070	70	55	40	16,2	11,0	3,7	1/2" NPTF
HAP0130	130	100	80	8,5	6,0	3,9	1/2" NPTF
HAP0180	180	150	100	6,1	4,7	2,6	1/2" NPTF
HAP0250	250	200	150	4,1	3,1	2,0	1/2" NPTF
HAP0400	400	320	240	2,6	1,8	1,2	1/2" NPTF
HAP0740	740	600	440	1,2	0,9	0,6	1/2" NPTF
HAP1300	1.300	1.000	770	0,4	0,3	0,2	9/16"-18UNF
HAP1900	1.900	1.500	1.100	0,7	0,5	0,3	9/16"-18UNF
HAP2900	2.900	2.300	1.800	0,3	0,2	0,1	9/16"-18UNF

BOLT TENSIONER PUMP

Bolt Tensioner Pump	Maximum Hydraulic Pressure (bar)			Flow (l/min)			Outlet Port
	Air 6.9 bar	Air 5.1 bar	Air 4.1 bar	20% Max. P	50% Max. P	80% Max. P	
LARZEP							Coupler
HAP2900BT	1.500	1.500	760	0,3	0,2	0,1	AZ3341