

PETROL HYDRAULIC PUMPS

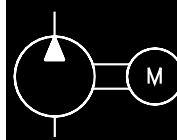

PETROL HYDRAULIC PUMPS



HAG

14-50 litres

700 bar

PUMPS

LARZEP advantages

- Powered by a gasoline engine. For operation in remote locations where electric supply is not available.
- **The manual control valve is easily converted from double acting to single acting operation.**
- Internal safety valve set at 700 bar to prevent overpressure.
- External adjustable pressure relief valve.
- Roll bar and wheel kits available as options on request.

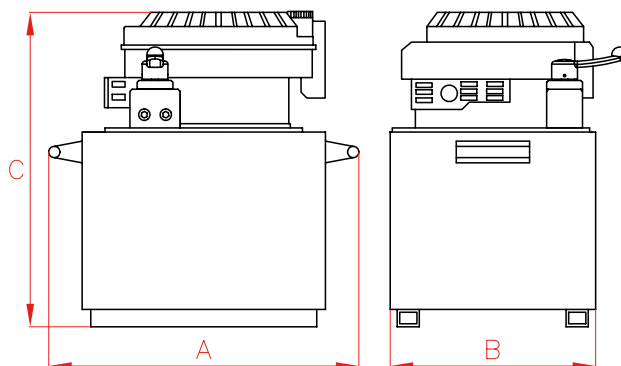

Capacity	A	B	C
l	mm	mm	mm
14	368	290	665
25	450	325	760
50	540	415	860

Tank	Flow at 700 bar	Flow at 60 bar	Valve Function	Single/A	Double/A	Power	Weight
l	l/min	l/min				kW	kg
14	0,51	-	Advance-Hold-Retract	HAG242	HAG244	3,6	39
25	0,51	-	Advance-Hold-Retract	HAG252	HAG254	3,6	63
50	0,51	-	Advance-Hold-Retract	HAG262	HAG264	3,6	96
14	0,36	4	Advance-Hold-Retract	HAG742	HAG744	3,6	36
25	0,36	4	Advance-Hold-Retract	HAG752	HAG754	3,6	60
50	0,36	4	Advance-Hold-Retract	HAG762	HAG764	3,6	93