



"innovation in its most functional form"

## PRODUCT DATA SHEET



# HP350D

## HYDRAULIC TWIN PORT SEALED HAND PUMP

### PRESSURE RATING:

1st STAGE: 13.8 bar (197 psi)

2nd STAGE: 700 bar (10,000 psi)

CAPACITY: 350cc

TOOL WEIGHT = 6kg (13.2 lbs)

### KIT COMPONENTS

- 1 x HP350D Pump Unit
  - 2 x 0-1000 bar (0-15,000 psi) Gauge
  - 2 x 3/8" Port Gauge Adaptor
  - 1 x Instruction Manual
  - 1 x Cardboard Packaging
- Product Code: HP350DMIN



MODEL	HP350D	
PUMP TYPE	TWO SPEED	
PRESSURE RATING (bar/psi)	1ST STAGE	13.8 (197)
	2ND STAGE	700 (10,000)
USABLE OIL CAPACITY (cc/in <sup>3</sup> )	350.0 (21.35)	
OIL VOLUME PER STROKE (cc/in <sup>3</sup> )	1ST STAGE	3.62 (0.221)
	2ND STAGE	0.77 (0.046)
MAX HANDLE EFFORT (kg/lb)	33 (72.75)	
PISTON STROKE (mm/in)	18.0 (0.71)	

### TOOL DESCRIPTION

The HP350D hydraulic hand pump unit is tailored for use with Equalizer International hydraulic equipment. Its output is regulated to 700 bar (10,000 psi) and is delivered from an output port threaded 3/8" NPT. The pump can be used with any 700 bar (10,000 psi) rated hydraulic equipment with an oil capacity of 350cc (21.35 in<sup>3</sup>) or less. The diaphragm oil reservoir means that, unlike conventional hand pump units, the HP350D is operable at all angles and is highly resistant to accidental spillage of hydraulic fluid. For further details please request an instruction manual.

### WEIGHTS AND DIMENSIONS

- Tool Only = 6 kg (13.2 lbs)
- GROSS KIT WEIGHT = 6.5 kg (14.3 lbs)

#### Packaging Dimensions:

250 x 180 x 600 mm (9.84" x 7.09" x 23.62")

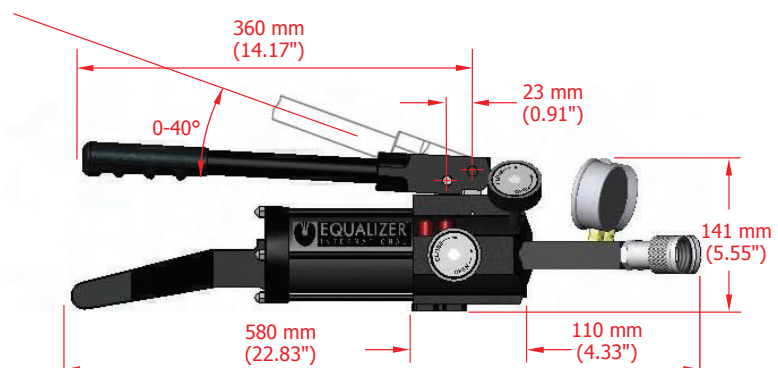
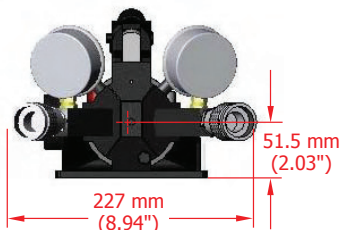

# HP350D

HYDRAULIC TWIN PORT

SEALED HAND PUMP



"innovation in its most functional form"

## RANGE OF APPLICATION

All hydraulic equipment with an oil capacity of 350cc (23.13 in<sup>3</sup>) or less and an operating pressure of 10,000 psi (700 bar)

## PARTS LIST AND EXPLODED DRAWING

ITEM	PART No.	DESCRIPTION	KIT QUANTITY	PUMP QUANTITY
01	720101-01	<b>PUMP HOUSING</b>		01
02	710601-01	<b>RESERVOIR</b>		01
	715100-01	<b>SERVICE KIT A:</b>		
03		- RESERVOIR BLADDER	01	01
04		- OIL FILTER	01	01
05		- O-RING	01	01
06		- REFILLING PLUG	01	01
	725200-01	<b>SERVICE KIT B:</b>		
07		- SCREW	04	04
08		- TAIL BASE	01	01
09		- SPRING WASHER	04	04
10		- NUT	04	04
	715300-01	<b>SERVICE KIT C:</b>		
11		- O-RING	01	01
12		- BACK-UP RING	01	01
13		- H.P. PISTON	01	01
14		- SNAP RING	01	01
15		- O-RING	01	01
16		- BACK-UP RING	01	01
17		- L.P. PISTON	01	01
	715400-01	<b>SERVICE KIT D:</b>		
18		- HANDLE	01	01
19		- YOKE	01	01
20		- PISTON PIN	01	01
21		- YOKE PIN	01	01
22		- RETAINING RING	01	01
23		- HANDLE GRIP	01	01
24		- SCREW	01	01
	715500-01	<b>SERVICE KIT E:</b>		
25		- YOKE BASE	01	01
26		- SPRING PIN	01	01
	715600-01	<b>SERVICE KIT F:</b>		
27		- RELEASE VALVE	01	01
28		- SCREW	01	01
29		- WASHER	01	01
30		- SEAL	01	01
31		- RELEASE KNOB	01	01
32		- SCREW	01	01
33		- COUPLERS	01	01
	715700-01	<b>SERVICE KIT G:</b>		
34		- CHECK BALL	01	01
35		- SPRING	02	02
36		- STEEL BALL	02	02
37		- OUTLET BALL	02	02
38		- SPRING	02	02
39		- COPPER WASHER	02	02
	715800-01	<b>SERVICE KIT H:</b>		
40		- VALVE COVER SCREW	02	02
41		- STEEL BALL	02	02
42		- SPRING END CAP	01	01
43		- L.P. SPRING	01	01
44		- O-RING	02	02
45		- OVERLOAD COVER	01	01
46		- SCREW	02	02
47		- CAP	01	01
48		- OVERLOAD COVER	01	01
49		- SCREW	01	01
		- CONE SEAT	01	01
		- CONE	01	01
		- LONG SEPARATOR	01	01
		- SPRING	01	01

ITEM	PART No.	DESCRIPTION	KIT QUANTITY	PUMP QUANTITY
50	715900-01	<b>SERVICE KIT I:</b>		
51		- BASE PLATE	01	01
		- SCREW	02	02
52	726000-01	<b>SERVICE KIT J:</b>		
53		- VALVE SCREW	01	02
54		- BACK-UP RING	01	02
30		- O-RING	01	02
31		- RELEASE KNOB	01	02
32		- SCREW	01	02
		- COUPLERS	01	02
55	716100-01	<b>SERVICE KIT K:</b>		
56		- SCREW	05	05
57		- CHECK BALL	04	04
	716200-01	<b>SERVICE KIT L:</b>		
58		- GAUGE COUPLER	01	02
		MALE		
59		- GAUGE	01	02
	716300-01	<b>SERVICE KIT M:</b>		
60		- GAUGE COUPLER	01	02
		FEMALE		
		- COUPLER	01	02
		- PORT GAUGE	01	02
		- ADAPTOR	01	02

