

"innovation in its most functional form"

PRODUCT DATA SHEET

FC10TE

HYDRAULIC FLANGE CLOSING TOOL

STANDARD KIT | MAXI KIT

CLOSING FORCE: 10 T (100 kN) per tool

CLOSING DISTANCE:
From 600mm (23.5") to 0

TOOL WEIGHT = 11 kg (24.25 lbs)

KIT COMPONENTS | STD

- 1 x FC10TE Tool
 - 2 x 10,000 psi (700 bar) 5T Hydraulic Cylinders
 - 1 x 10,000 psi (700 bar) Hydraulic Hose
 - 1 x 10,000 psi (700 bar) Hydraulic Hand Pump
 - 1 x Instruction Manual
 - 1 x Carry Case with Foam Inserts
- Product Code: FC10TESTD



KIT COMPONENTS | MAXI

- 2 x FC10TE Tool
 - 4 x 10,000 psi (700 bar) 5T Hydraulic Cylinders
 - 2 x 10,000 psi (700 bar) Hydraulic Hose
 - 1 x 10,000 psi (700 bar) HP350D Hydraulic Hand Pump
 - 1 x Instruction Manual
 - 1 x Carry Case with Foam Inserts
- Product Code: FC10TEMAX



WEIGHTS AND DIMENSIONS

- Tool Weight = 11 kg (24.25 lbs)
- Case Weight = 9 kg (19.84 lbs)
- Gross Weight = 23.5 kg (51.8 lbs)

Packaging Dimensions:
890 x 570 x 165mm (35.04" x 22.44" x 6.50")

- Tool Weight = 11 kg (24.25 lbs)
- Case Weight = 9 kg (19.84 lbs)
- Gross Weight = 36.5 kg (80.46 lbs)

Packaging Dimensions:
890 x 570 x 165mm (35.04" x 22.44" x 6.50")

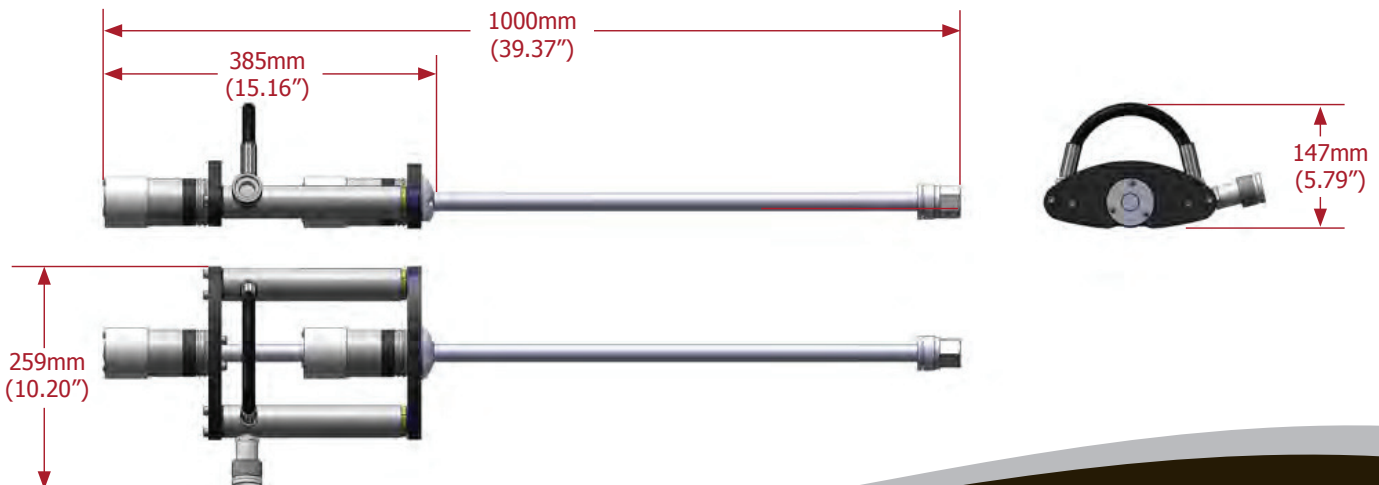

info@equalizerinternational.com
www.equalizerinternational.com

FC10TE

HYDRAULIC FLANGE CLOSING TOOL

MAXI KIT



"innovation in its most functional form"

RANGE OF APPLICATION

The FC10TE is applicable to all flanges with a bolt hole diameter of 25.4mm (1") or greater.

This includes ANSI, DIN, SPO, ASME, API and BS flanges.

For a detailed range of application please refer to the FC10TE instruction manual.

PARTS LIST AND EXPLODED DRAWING

ITEM	PART No.	DESCRIPTION	QUANTITY
01	070001-01	READ INSTRUCTION STICKER	01 each
02	300901-01	HYDRAULIC COUPLER	01 each
03	750101-01	FRONT PLATE	01 each
04	750201-01	REAR PLATE	01 each
05	752101-01	SCKT HEAD SCREW	04 each
06	752201-01	SCKT HEAD SCREW	04 each
07	752301-01	CYLINDER NOSE SCREW	02 each
08	752401-01	CYLINDER NOSE ADAPTOR	02 each
09	752501-01	5T H. CYLINDERG	02 each
10	752506-01	SET SCREW	01 each
11	752601-01	COUPLING HOSE	01 each
12	752701-01	BALL WASHER	01 each
13	752801-01	PULL ROD	01 each
14	752901-01	ROD WASHER	01 each
15	753001-01	NUT RETAINING SLEEVE	02 each
16	753501-01	RATCHET NUT	02 each
17	754001-01	PULL NUT	01 each
18	752510-01	CYLINDER REPAIR KIT (Not illustrated)	01 kit

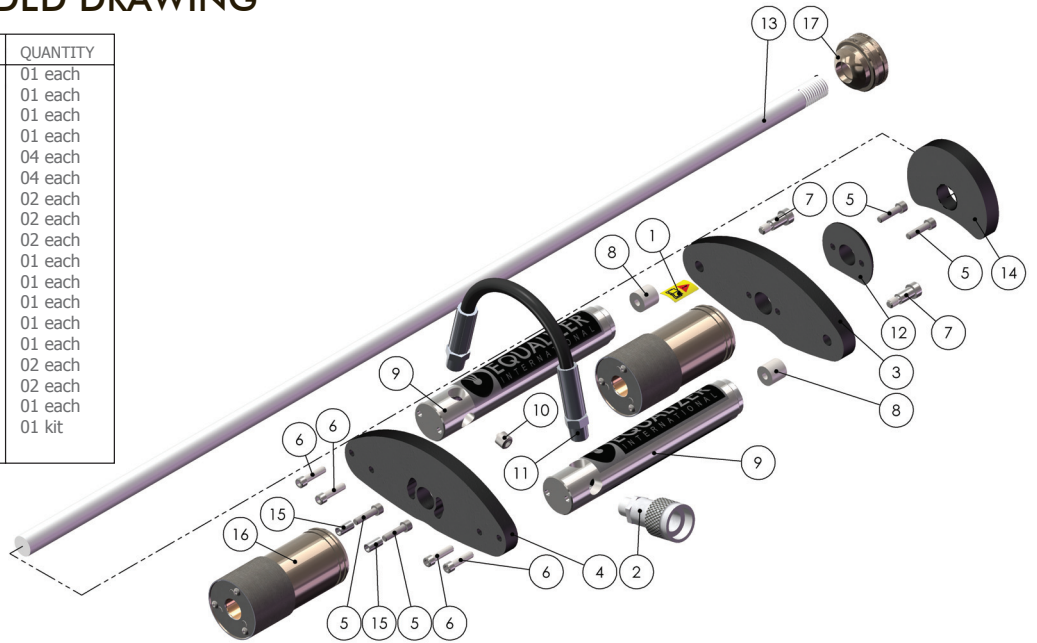

RATCHET NUT PARTS LIST AND EXPLODED DRAWING

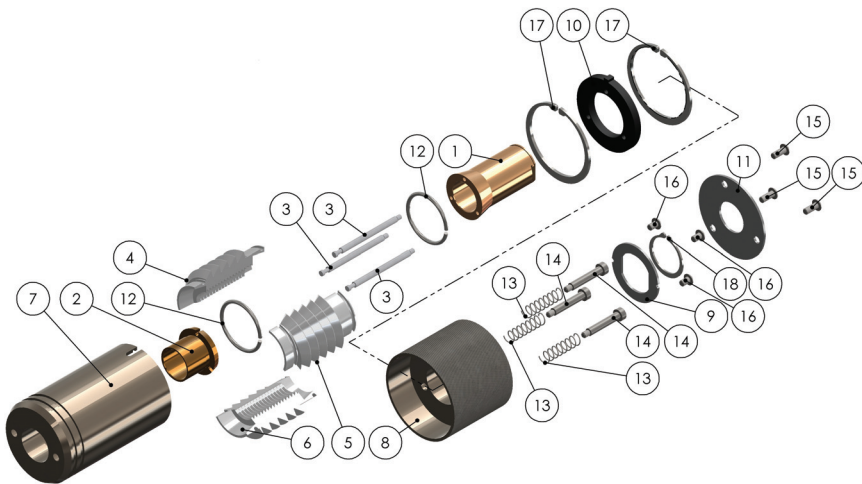

ITEM	PART No.	DESCRIPTION	QUANTITY
01	750301-01	CAGE REAR RING	01 each
02	750401-01	CAGE FRONT RING	01 each
03	750501-01	CAGE SIDE BAR	03 each
04	750601-01	COLLET SEGMENT 1	01 each
05	750701-01	COLLET SEGMENT 2	01 each
06	750801-01	COLLET SEGMENT 3	01 each
07	751001-01	NUT BODY	01 each
08	751101-01	NUT CAP	01 each
09	751201-01	LOCK WASHER	01 each
10	751301-01	REACTION PLATE	01 each
11	751401-01	END CAP	01 each
12	751501-01	COLLET RETURNIGN SPRING	02 each
13	751601-01	CAP RETAINING SPRING	03 each
14	751701-01	CAP RETAINING SCREW	03 each
15	751801-01	BUTTON HEAD SCREW	03 each
16	751802-01	BUTTON HEAD SCREW	03 each
17	751901-01	CIRCLIP INTERNAL	02 each
18	752001-01	CIRCLIP EXTERNAL	01 each