

- Designed to split nuts from 13 mm up 100mm AF size
- Splitting-cutting feature up to 44 RC hardness
- Up to 120 ton by 700 bar hydraulic system
- Compact easy to use with spring assisted return piston
- Blades can be re-sharpened or replaced as and when required.
- Angled body ensures clearance on flanges and flat surfaces.
- Made in Germany quality by Padima GmbH

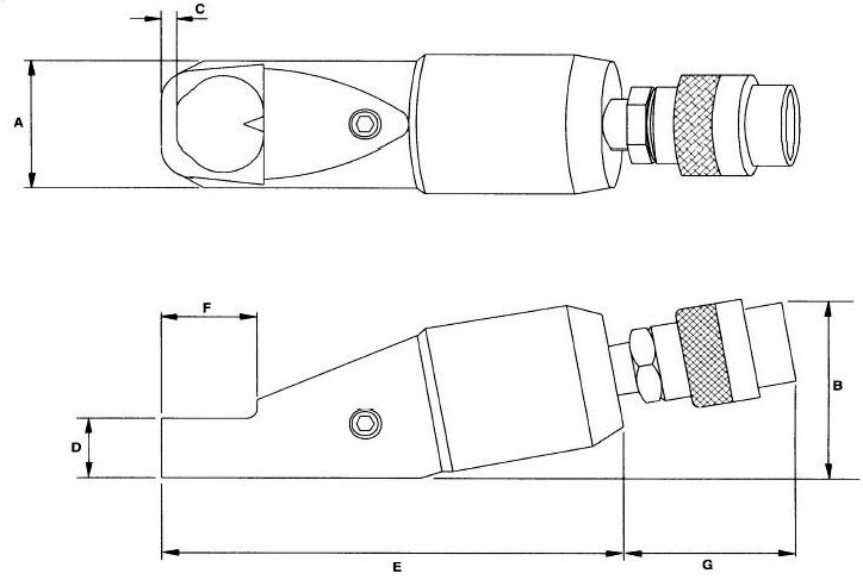

Code	Birim	MSP1319	MSP1924	MSP2432	MSP3241	MSP4150	MSP5060	MSP6075	MSP7590	MSP90105
Hexagon Size	mm	13-19	19-24	24-32	32-41	41-50	50-60	60-75	75-90	90-105
Metrical Size	M	6-12	12-16	16-22	22-27	27-33	33-39	39-48	48-60	60-72
Capacity	ton	5	10	15	20	35	50	90	125	140
Oil Capacity	cm3	15	25	40	62	123	191	650	850	950
Weight	kg	1	2	3	4	8	12	34	65	100
Nut height *	mm	9,6	12,8	17,6	21,6	26,4	31,2	38,4	48	57,6
A	mm	40	54	64	75	94	106	156	186	210
B	mm	49	62	76	86	106	125	183	212	245
C	mm	7	10	13	17	21	23	26	30	33
D	mm	19	26	29	36	45	54	72	95	105
F	mm	28	40	51	66	74	90	110	127	147

* Allowed nut height – metrical size * 0,8 =